

Icon Pushfit Couplings

- Can be installed in 30 seconds or less
- Quick and easy alternative to a standard coupling
- Superior joint stability compared to external couplings
- Pushfit connection – no tools required
- Can be easily removed and re-used
- Watertight connection on any pipe material
- No need to expose external surface of pipe
- Removes internal joint step that is created by connecting two different pipe materials with conventional couplings
- Creates a smooth transition between pipe invert levels
- Improved jetting resistance
- Withstands internal pressure of up to 2.5bar
- Conforms to all testing requirements of WIS 4-41-01 and BS EN 295-4:2013



Fernco manufactures a wide range of couplings that connect rainwater and wastewater pipelines using the internal surface, we call these 'Icon' (internal connection) couplings.

Traditionally, flexible couplings connect to the outside of the pipelines; when this connection is made in accordance with the above-mentioned standards, a joint gap is required between the connecting pipes, this is to allow for any angular deflection which may be caused by subsequent ground movement. This gap has been found to negatively affect the natural flow of a sewer system. The use of an Icon internal coupling removes this issue, by creating a smooth transition which improves the flow of materials.

Fit horizontally or vertically

for above or below ground applications

Fernco has found that with the introduction of features such as tapered edges, which allow angular misalignment, but maintain a smooth pipe transition and with the use of highly engineered plastics for improved shear support/ deformation resistance, the Icon coupling can improve flow and sewer hydraulics when compared to conventional external pipe connections.

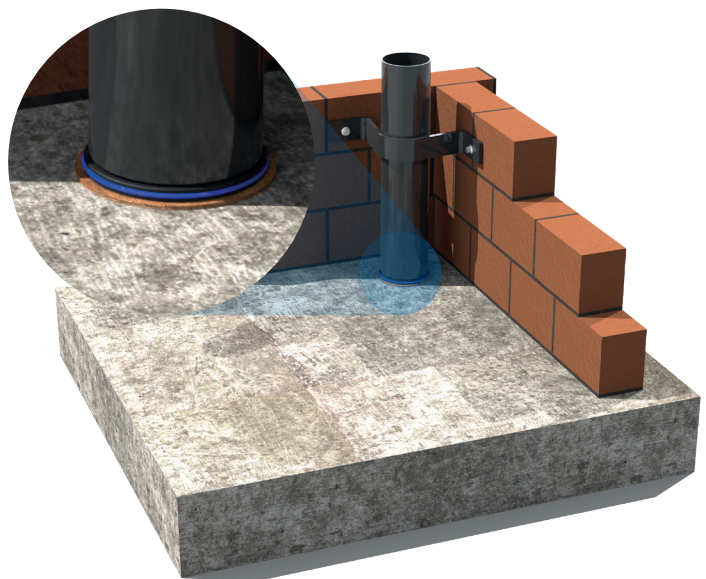

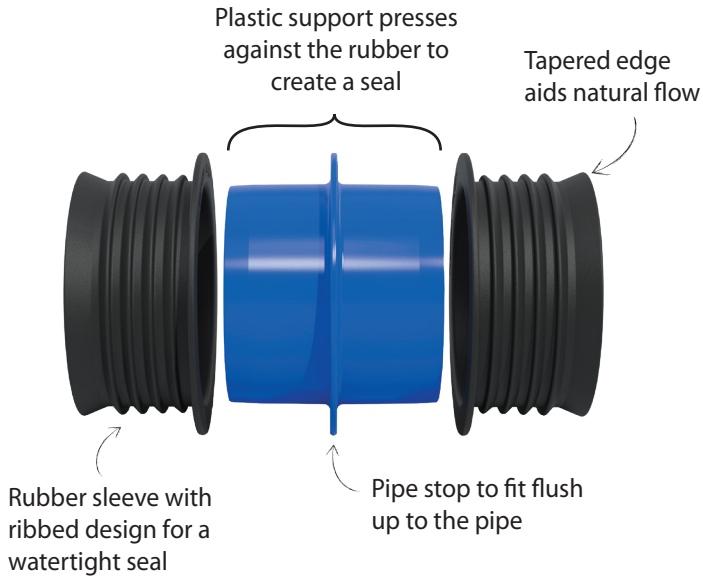

Product Code	ICXXXP
Description	Fernco Icon Pushfit Coupling
Size Range	93 - 153mm
Material	ABS EPDM
Pressure Rating	2.5bar, 36.25psi
Jetting Resistance	230bar
Temperature Range	-50°C to 80°C constant, 100°C intermittent
Standards	WIS 4-41-01 BS EN 681-1:1996 BS EN 295-4:2013

Product Code	Nominal Dia. (mm)	Size (mm)	Description
IC95P	100	93 - 98	For connecting two DN100 pipes.
IC95-100P	100	Pipe 1: 93 - 98 Pipe 2: 99 - 104.5	For connecting two DN100 pipes.
IC100P	100	99 - 104.5	For connecting two DN100 pipes.
IC150P	150	147.5 - 153	For connecting two DN150 pipes.
IC95-150P	100-150	Pipe 1: 93 - 98 Pipe 2: 147.5 - 153	For connecting DN100 pipes to DN150 pipes.
IC100-150P	100-150	Pipe 1: 99 - 104.5 Pipe 2: 147.5 - 153	For connecting DN100 pipes to DN150 pipes.

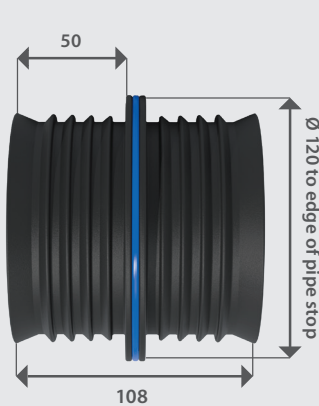

4" Inch Straight Connection

(IC95P, IC95-100P, IC100P)

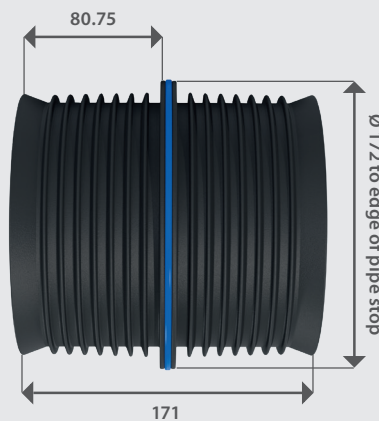

6" Inch Straight Connection

(IC150P)

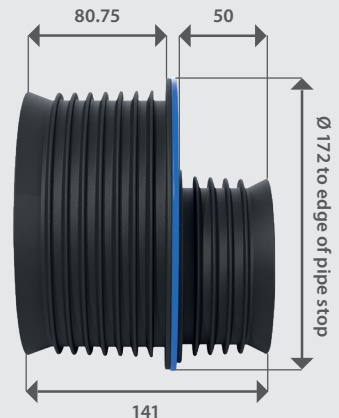

4" to 6" Inch Adaptor Connection

(IC95-150P, IC100-150P)

Measurements shown are (mm)

Note: The lip in the rubber is tapered to eliminate steps in the joint and aid natural flow. Bore reduction has been kept to a minimum and is deemed suitable for drainage applications because of these improvements to flow.

Installation

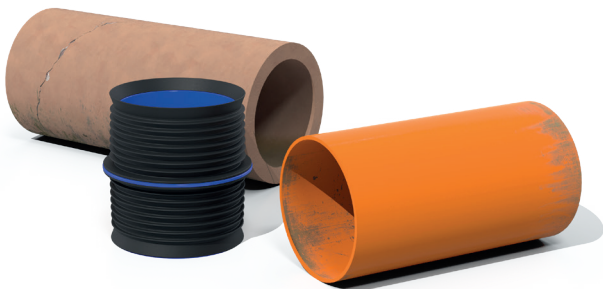

1. Clean the internal surface of both pipes from slurry and debris.

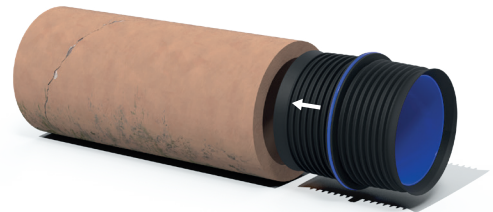

2. Push the Icon into pipe 1 up to the product's pipe stop.



3. Push pipe 2 onto the opposite end of the Icon.

NOTE: Ensure that the tapered edge on the rubber sleeve does not fold back when inserting into the pipe. Lubricant may be required, if so use sparingly, water is recommended.

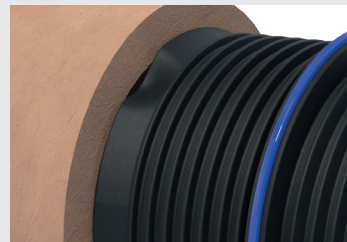

General Information

Quality, Standards and Approvals

Fernco has been certified by the British Standards Institution (BSI) as a company of assessed capability, with a quality management system which meets the requirements of BS EN ISO 9001:2015

Fernco UK, part of a global group of companies, are the leaders in wastewater connection innovation; utilising the most advanced methods and techniques for precision-manufactured products, all of which comply with or exceed relevant British and European standards to ensure reliability and sustainability.

Environment

Fernco operate Environmental Management Systems which are certified to ISO 14001: 2015.

Supply

Fernco are proud members of the Builders Merchants Federation (BMF). All Fernco products are supplied through a national and global network of distribution and merchant partners. For stockist details, contact Fernco.

Technical Support

Fernco have a team of product experts on hand to support all customers with technical support and advice.

Contact Fernco Technical Department:

Tel: +44 (0) 1226 344100

Email: technical@fernco.co.uk

Enquiries

UK Sales:

Tel: +44 (0) 1226 340 888

Email: sales@fernco.co.uk

International Sales:

Tel: +44 (0) 1226 344 105

Email: export.dept@fernco.co.uk